

Other Items

TRC 100 Prepuller

This prepuller is designed to pull heavy webbing before it goes through the TRC cutters. The prepuller works especially well for webbing that is loose in boxes and is too heavy for the cutter alone. This is a stand alone unit and requires 110v electricity.

PP7.....\$1345.00

Manual Hot Knife

This is a Hot Knife with a 4 1/2" Blade that is activated by a footswitch control. It has variable heat control. 110V and small air supply are required.

HC4-FS \$1300.00

Radius cutters

We can custom build radius cutters for belt ends, dog collars, horse halters ect . These cutters are semi automatic and are activated by a foot switch. Just send us a sample of your webbing and a drawing of the radius and we will give you a price. Prices start at about \$1050.00

Parts

Since we build everything, parts are always available.

Terms

Payment in full before shipping.

Guarantee

6 month warranty on all parts and labor except heating elements. No questions asked. If it quits, we fix it!

Comments

Some statements I have received from customers.

"I didn't know it would do that."

"The reason we chose yours is that it was so simple."

"This is the best buy on the market."

"It used to take one of us to cut the webbing, now it takes two... we just sit and watch it."

To place an order or for more information call your local distributor.



TRC Industries

P.O. Box 485

Nevada, MO 64772

call and ask for Jim or Jon

Phone 417-667-4477

Fax 417-667-4039

email sales@trcind.com
web site <http://www.trcind.com>

“A Digital Strip Cutter For Only \$4045?”

“Why does your machine cost so much less than everybody else’s?”

This is the question we hear most often. There are several reasons and we will give you just a few.

First, we keep it simple. Once we took a name brand strip cutter in on trade and we gave it the once over and found out it was made overseas (we build ours here). We also noticed it has 5 belts and chains (we use only one) that had to turn before it could make a cut. Seemed pretty complicated to us and we saw no need for it.

Second, we use as many off the shelf components as we can. Less tooling cost that way.

Third, we have low overhead and low taxes. We own our building and equipment. No lease payments, no machinery payments and the savings are passed on to you. These are some of the ways we save you money.

We feel our motto says it all...

We Keep it Simple to Build and Simple to Operate.

TRC 1000 Strip Cutter

Models in Hot or Cold

These are our basic models that were designed for small companies that don't need expensive high speed machines and don't want to spend a fortune to automate. These machines feature: Digital control that is very user friendly. Single speed motor with feed rate of 7.5 inches per second. Temperature control (hot cutter version only) and cut time are variable to allow for maximum production. Maximum length is 50 feet and the length tolerance is 3/16 of an inch per 60 inches. Two different knife widths are available 4 1/2" or 7".

Power requirements are 110V, 50# of air pressure and a table to set it on. These machines are ready to use when you receive them, nothing else to buy. These machines can also be upgraded to high speed machines at a later date if you desire.

TRC 1000 CS Dimensions are 14'' x 7'' x 14'' for the cutter, 6'' x 8'' x 12'' for the roll stand and 10'' x 14'' x 6'' for the control panel. Roll stand is included.

(shown below)

HC4-CS or

CC4-CS Only \$4045.00

HC7-CS or

CC7-CS Only \$4445.00

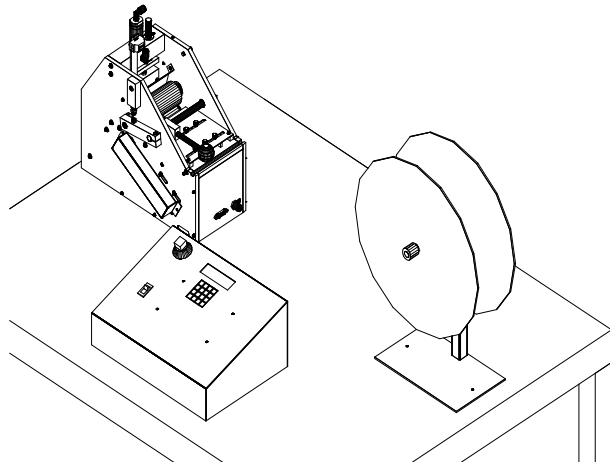

TRC 1000 VSAA

Alternating Angle

The TRC 1000 AA is an all digital alternating angle cutter. The angles are set digitally at the control panel. NO wrenches to use. The machine can be set at + 45 to - 45 degrees or any angle between these numbers. For instance you can set it to cut a +10 and a -34 degrees or any combination you want. All this is done at the keyboard making it a very easy machine to use. The feed rate for this machine is up to 22 inches per second with variable dwell time and heat range. Maximum length of cut is 50 feet.

Machine dimensions are 18'' x 10'' x 14'' for the cutter, 6'' x 8'' x 12'' for the roll stand and 10'' x 14'' x 6'' for the control panel. Roll stand included.

(shown at the right)

HC5-VSAA Only \$7345.00

TRC 1000 VS Strip Cutter

Variable Speed Drive

This is a variable speed version of our basic model. It features the same easy to use digital control but has the variable speed option. This feature will give you a feed rate of up to 22 inches per second with length tolerance of 3/16'' per 60 inches with a maximum length of 50 feet. If you need fast and accurate production then this is the machine for you.

Power requirements are 110V, 50# air pressure and a table to set it on.

TRC 1000 VS Dimensions are 14'' x 7'' x 14'' for the cutter 6'' x 8'' x 12'' for the roll stand and 10'' x 14'' x 6'' for the control panel. Roll stand is included.

(shown to the left)

HC4-VS or

CC4-VS Only \$4245.00

HC7-VS or

CC7-VS Only \$4645.00

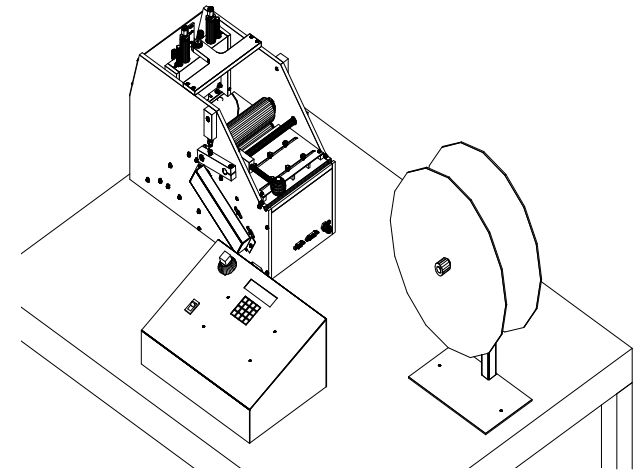

Options

Cold Cutter Head only. You can buy this and use with your existing TRC 1000 control box to run it.

CC4 \$3025.00

High torque motor option. This motor has twice the power of our standard motor for pulling heavier webbing.

HT \$250.00

Cutoff Switch - This will stop the machine when it runs out of material. All program data and count are saved. Just change the roll of material and continue on.

ICO \$250.00

Multi-lingual language for machine programming. If you have a special need for different languages or for metric measurements, give us a call.

Custom Machines

Occasionally we get asked to build custom machines. If you have such a need let us know. We can't build every machine that comes along but if it is within our capabilities we would like the chance to quote a price. If you have any more questions feel free to call and ask for Jim or Jon.

TRC Industries

Hot Knife Strip Cutter

830 E. Hickory St. - P.O. Box 485 - Nevada, MO 64772 - Phone 417-667-4477 - Fax 417-667-4039

email sales@trcind.com

Web site on the internet <http://www.trcind.com>

Call
and
ask
for
Jim or Jon

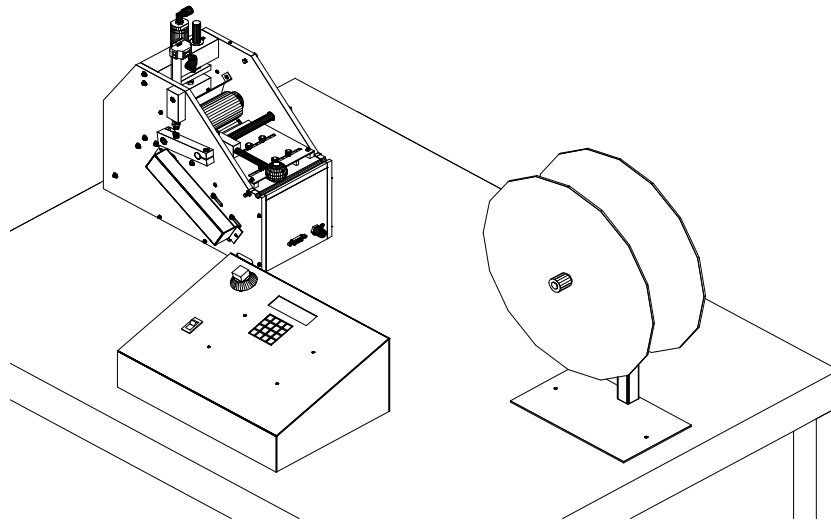

Call
and
ask
for
Jim or Jon

These are our basic models that were designed for small companies that don't need expensive high speed machines and don't want to spend a fortune to automate. These machines feature: Digital control that is very user friendly. Single speed motor with feed rate of 7.5 inches per second. Temperature control and cut time are variable to allow for maximum production. Maximum length is 50 feet and the length tolerance is 3/16 of an inch per 60 inches (depending on material). Two different knife widths are available 4 1/2" or 7".

Power requirements are 110V, 50# of air pressure and a table to set it on. These machines are ready to use when you receive them, nothing else to buy. These machines can also be upgraded to high speed machines at a later date if you desire.

TRC 1000 CS Dimensions are 14" x 7" x 14" for the cutter, 6" x 8" x 12" for the roll stand and 10" x 14" x 6" for the control panel. Roll stand is included.

HC4-CS Only \$4045.00 27# 10" wide

HC7-CS Only \$4445.00 30# 12" wide 15 1/2" tall 15" long

Options

- Variable Speed Option (**VS**) - This option will give you a feed rate of up to 22 inches per second with length tolerance of 3/16" per 60 inches with a maximum length of 50 feet. **Now only \$200.00**
- High torque motor option (**HT**) - This motor has twice the power of our standard motor for pulling heavier webbing. **\$250.00** adds 1 1/2# to weight
- Cutoff Switch option (**ICO**) - This will stop the machine when it runs out of material. All program data and count are saved. Just change the roll of material and continue on. **\$250.00**
- Times 10 option (**T10**) - This will give you upto a 500 foot cutting length with a minor tolerance loss. **\$150.00**
- Other special applications such as remote start/stop palm switches, auxillary inputs or outputs, hole punching, etc. please call for a price quote.
- Multi-lingual language for machine programming. If you have a special need for different languages or for metric measurements, give us a call.

TRC Industries

Cold Knife Strip Cutter

830 E. Hickory St. - P.O. Box 485 - Nevada, MO 64772 - Phone 417-667-4477 - Fax 417-667-4039

email sales@trcind.com

Web site on the internet <http://www.trcind.com>

Call
and
ask
for
Jim or Jon

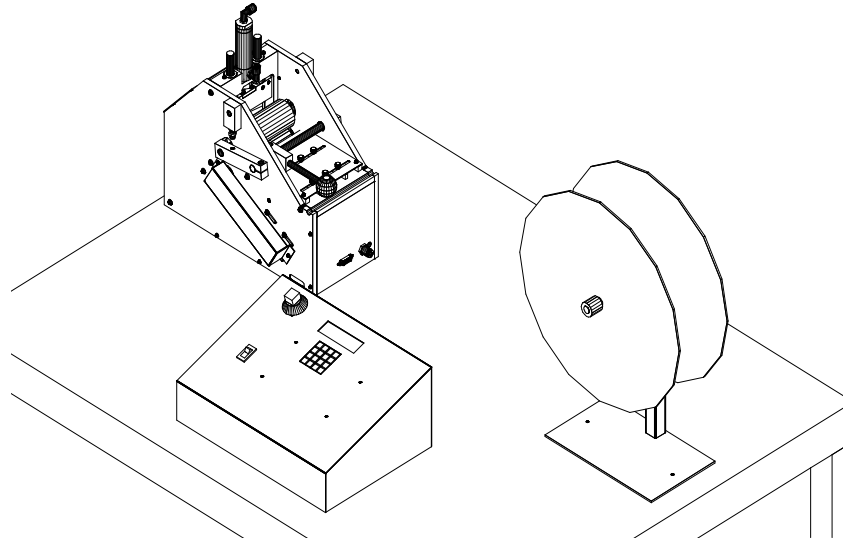

Call
and
ask
for
Jim or Jon

These are our basic models that were designed for small companies that don't need expensive high speed machines and don't want to spend a fortune to automate. These machines feature: Digital control that is very user friendly. Single speed motor with feed rate of 7.5 inches per second. Cut time is variable to allow for maximum production. Maximum length is 50 feet and the length tolerance is 3/16 of an inch per 60 inches (depending on material). Two different knife widths are available 4 1/2" or 7".

Power requirements are 110V, 50# of air pressure and a table to set it on. These machines are ready to use when you receive them, nothing else to buy. These machines can also be upgraded to high speed machines at a later date if you desire.

TRC 1000 CS Dimensions are 14" x 7" x 14" for the cutter, 6" x 8" x 12" for the roll stand and 10" x 14" x 6" for the control panel. Roll stand is included.

CC4-CS Only \$4045.00 25# 10" wide
CC7-CS Only \$4445.00 30# 12" wide 15 1/2" tall 15" long

Options

- Variable Speed Option (**VS**) - This option will give you a feed rate of up to 22 inches per second with length tolerance of 3/16" per 60 inches with a maximum length of 50 feet. **Now only \$200.00**
- High torque motor option (**HT**) - This motor has twice the power of our standard motor for pulling heavier webbing. **\$250.00** adds 1 1/2# to weight
- Cutoff Switch option (**ICO**) - This will stop the machine when it runs out of material. All program data and count are saved. Just change the roll of material and continue on. **\$250.00**
- Times 10 option (**T10**) - This will give you upto a 500 foot cutting length with a minor tolerance loss. **\$150.00**
- Other special applications such as remote start/stop palm switches, auxillary inputs or outputs, hole punching, etc. please call for a price quote.
- Multi-lingual language for machine programming. If you have a special need for different languages or for metric measurements, give us a call.

TRC Industries

Hot Knife Strip Cutter

830 E. Hickory St. - P.O. Box 485 - Nevada, MO 64772 - Phone 417-667-4477 - Fax 417-667-4039

email sales@trcind.com

Web site on the internet <http://www.trcind.com>

Call
and
ask
for
Jim or Jon

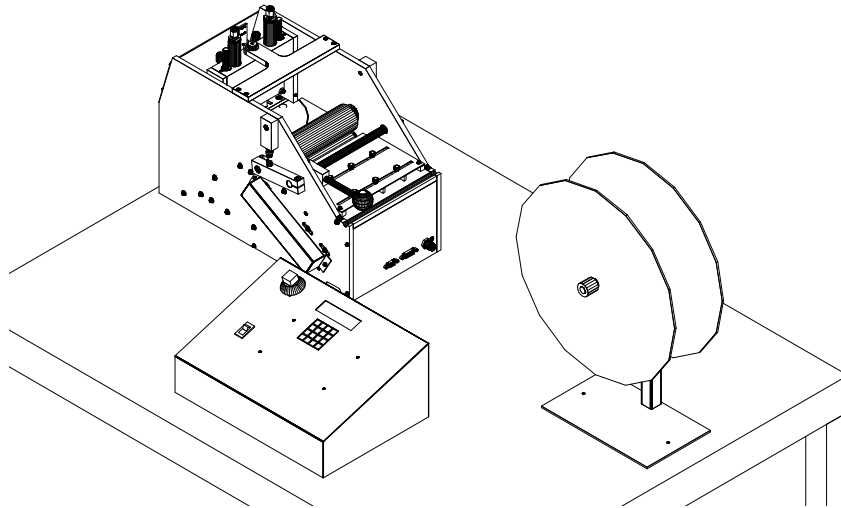

Call
and
ask
for
Jim or Jon

TRC 1000 Alternating Angle

The TRC 1000 AA is an all digital alternating angle cutter. The angles are set digitally at the control panel. NO wrenches to use. The machine can be set at + 45 to - 45 degrees or any angle between these numbers. For instance you can set it to cut a +10 and a -34 degrees or any combination you want. All this is done at the keyboard making it a very easy machine to use. The feed rate for this machine is up to 22 inches per second with variable dwell time and heat range. Maximum length of cut is 50 feet. Machine dimensions are 18'' x 10'' x 14'' for the cutter , 6' x 8'' x 12'' for the roll stand and 10'' x 14'' x 6'' for the control panel. Roll stand included.

HC5-VSAA Only \$7345.00

Options

- Cutoff Switch option (ICO) - This will stop the machine when it runs out of material. All program data and count are saved. Just change the roll of material and continue on. **\$250.00**
- Other special applications such as remote start/stop palm switches, auxillary inputs or outputs, etc. please call for a price quote.
- Multi-lingual language for machine programming. If you have a special need for different languages or for metric measurements, give us a call.

TRC Industries

TRC Prepuller

830 E. Hickory St. - P.O. Box 485 - Nevada, MO 64772 - Phone 417-667-4477 - Fax 417-667-4039

email sales@trcind.com

Web site on the internet <http://www.trcind.com>

**Call
and
ask
for
Jim or Jon**

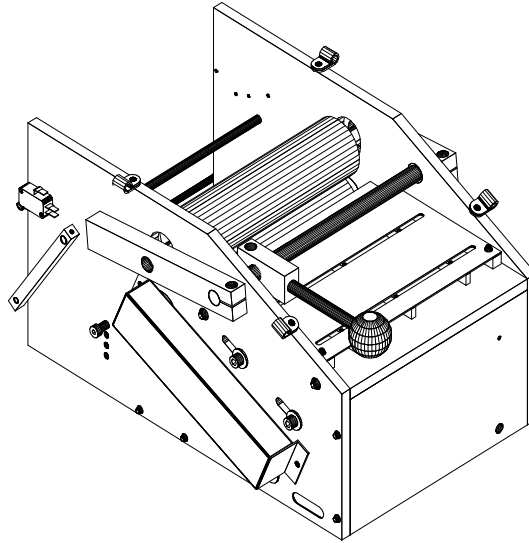

**Call
and
ask
for
Jim or Jon**

TRC Prepuller

This prepuller is designed to pull heavy webbing before it goes through the TRC cutters. The prepuller works especially well for webbing that is loose in boxes and is too heavy for the cutter alone. This is a stand alone unit and requires 110v electricity.

PP4 N/A

PP7 Only \$1345.00 22#

11" wide 14" long 8" tall

shipping weight approx 25#

elastic

optional cutoff switch interfacing

multiple guides

variable on time for loop control

PP4 is currently not available - PP7 is substituted at PP4 prices

TRC Industries

Hot Knife Strip Cutter

830 E. Hickory St. - P.O. Box 485 - Nevada, MO 64772 - Phone 417-667-4477 - Fax 417-667-4039

email sales@trcind.com

Web site on the internet <http://www.trcind.com>

**Call
and
ask
for
Jim or Jon**

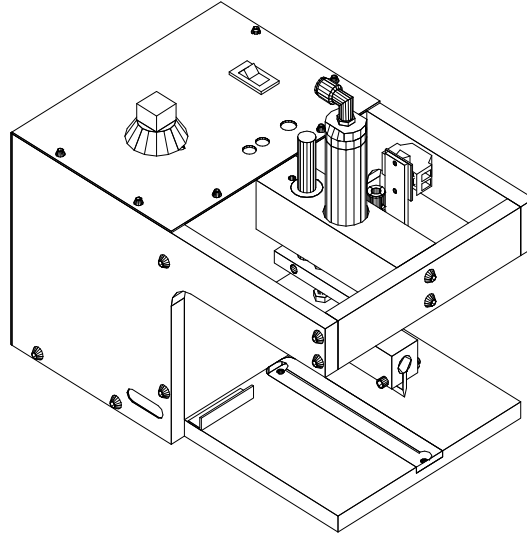

**Call
and
ask
for
Jim or Jon**

This cutter was designed for low volume production that does not require automation. It has a variable temperature control and is operated by a footswitch to leave both hands free to hold the webbing. This cutter is just the right size to place in front of or behind a sewing machine, the blade/block combination may be changed to cut a radius end or punch holes.

It requires 110V electricity and 50# of air pressure and a table to set it on. Machine dimensions are 12"D x 8 1/2"W x 10"H. This cutter only weighs 18 pounds.

HC4-FS Only \$1300.00 shipping weight about 25#

(Radius cutting and hole punching attachments sold separately. Call for a quote on your particular application.)

TRC Industries

Ultra-Sonic Strip Cutter

830 E. Hickory St. - P.O. Box 485 - Nevada, MO 64772 - Phone 417-667-4477 - Fax 417-667-4039

email sales@trcind.com

Web site on the internet <http://www.trcind.com>

Call
and
ask
for
Jim or Jon

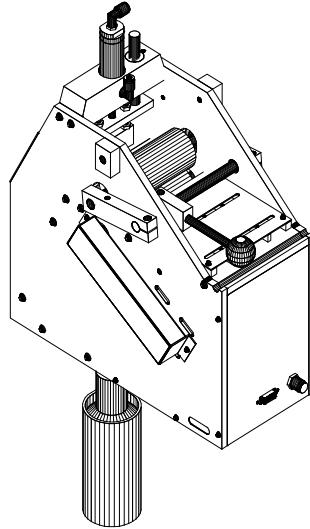

Call
and
ask
for
Jim or Jon

This machine features the same user friendly digital control as our other automatic machines, single speed motor with feed rate of 7.5 inches per second. Cut time are variable to allow for maximum production. Maximum length is 50 feet and the length tolerance is 3/16 of an inch per 60 inches.

Power requirements are 110V, 50# of air pressure and a table to set it on. These machines are ready to use when you receive them, nothing else to buy. These machines can also be upgraded to high speed machines at a later date if you desire.

TRC 1000 CS Dimensions are 18''D x 7''W x 14''H for the cutter, 6'' x 8'' x 12'' for the roll stand and 10'' x 14'' x 6'' for the control panel. Roll stand is included.

SC4-CS \$call for pricing on your application

Options

- Variable Speed Option (**VS**) - This option will give you a feed rate of up to 22 inches per second with length tolerance of 3/16'' per 60 inches with a maximum length of 50 feet. **Now only \$200.00**
- High torque motor option (**HT**) - This motor has twice the power of our standard motor for pulling heavier webbing. **\$250.00** (adds 1 1/2# to weight)
- Cutoff Switch option (**ICO**) - This will stop the machine when it runs out of material. All program data and count are saved. Just change the roll of material and continue on. **\$250.00**
- Times 10 option (**T10**) - This will give you upto a 500 foot cutting length with a minor tolerance loss. **\$150.00**
- Other special applications such as remote start/stop palm switches, auxillary inputs or outputs, hole punching, etc. please call for a price quote.
- Multi-lingual language for machine programming. If you have a special need for different languages or for metric measurements, give us a call.

TRC 1000 Optional Machine Attachments

The **HC4-15 and HC7-15 Stripper Plates** keep your material down after cutting, eliminating bunching up behind the cutting blade. Wide opening in the back for ease of initial material insertion. Usually used with lighter weight materials that tend to stick to the knife.

HC4-15.....\$25.00

HC7-15.....\$35.00

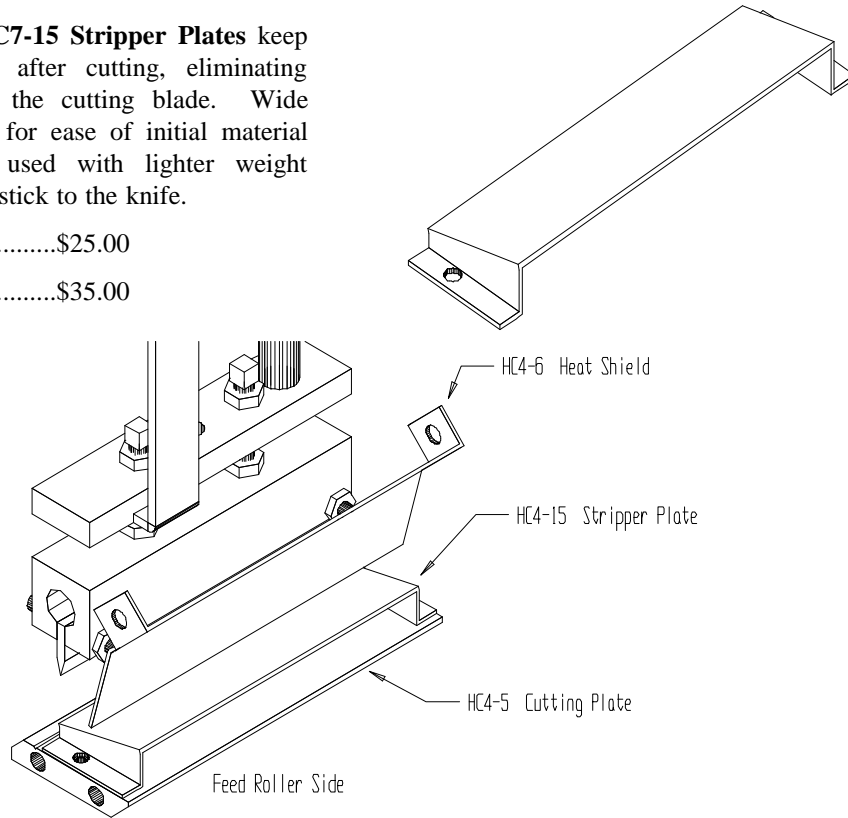

AM4-15 and AM7-15 Tensioner Plates are spring loaded attachments designed to keep constant tension on your material to improve length consistency in elastic type goods. Easy installation on all existing TRC 1000 machines.

AM4-15.....\$55.00

AM7-15.....\$65.00

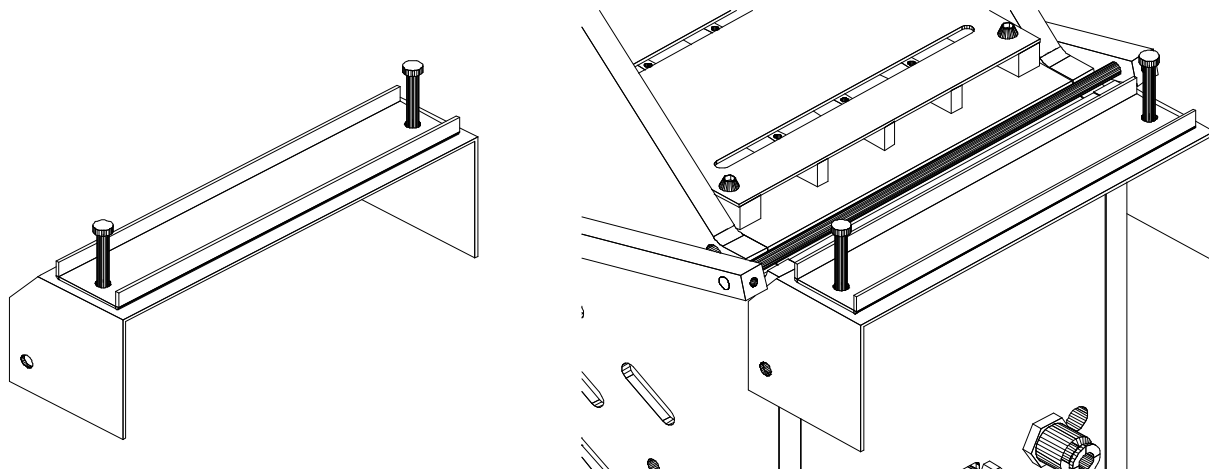

TRC 1000 Optional Machine Attachments

Alternating Angle Tunnel Secondary Guide.

This secondary guide goes between the feed rollers and the knife blade. Designed to keep your light weight materials down and in the center of your cutting blade. These guides are custom manufactured for your material.

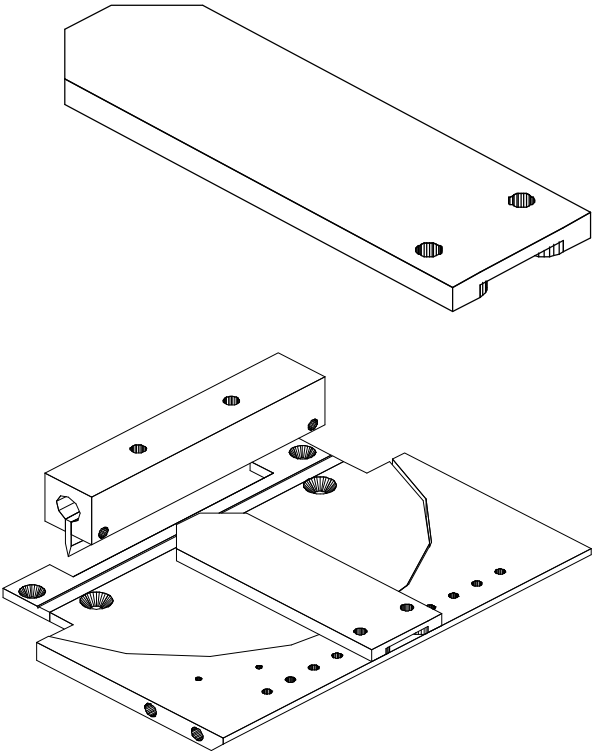

New for 2003!

The TRC Mini Cutter

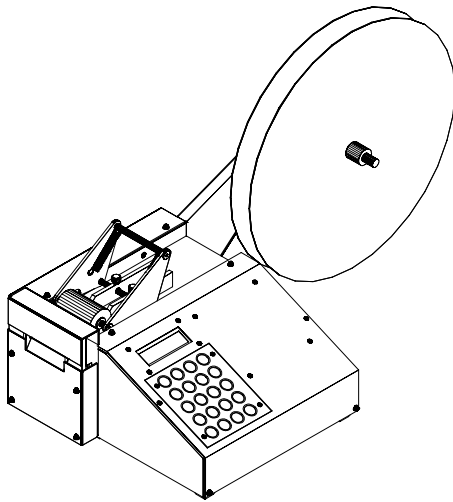

Made in the USA

Now Only \$1995.00 !!

The MC machine is a small, portable cutting machine. Designed to cold cut lighter weight ribbons and material up to 1 1/2" wide. With an 18" x 12" footprint and only 9 1/2" tall, it can sit just about anywhere. It's totally electric. Just plug it in and turn it on, load a roll of material and your ready to start cutting it up.

Specifications

120 volt operation
144" length limit
18" wide x 12 deep x 9 1/2" tall - excluding a roll of material
programmable feed rate from 1 to 12 inches per second
length calibration for different types of materials

1 1/2" width capacity
weighs approximately 40 lbs.

Example Cutting Performance

Cutting 3" long pieces over an 8 hour day will yield over *15,000 pieces cut. That's 25 50 yard rolls of material.

Options - We've got a whole bunch of options planned for this unit.

Material Runout Sensor - automatically stops the machine when the roll of material runs out

Multi language options - This option allows the prompts to be displayed in one of two different languages, also includes instruction books in both languages.

Metric measuring option - allows the user to enter the length in metric units (mm)

Program storage option - allows frequently used programs to be stored and recalled

MC Interface - Remote monitoring and programming with a PC. It can also store all your separate job information with the optional PC program.

* Actual performance may vary.

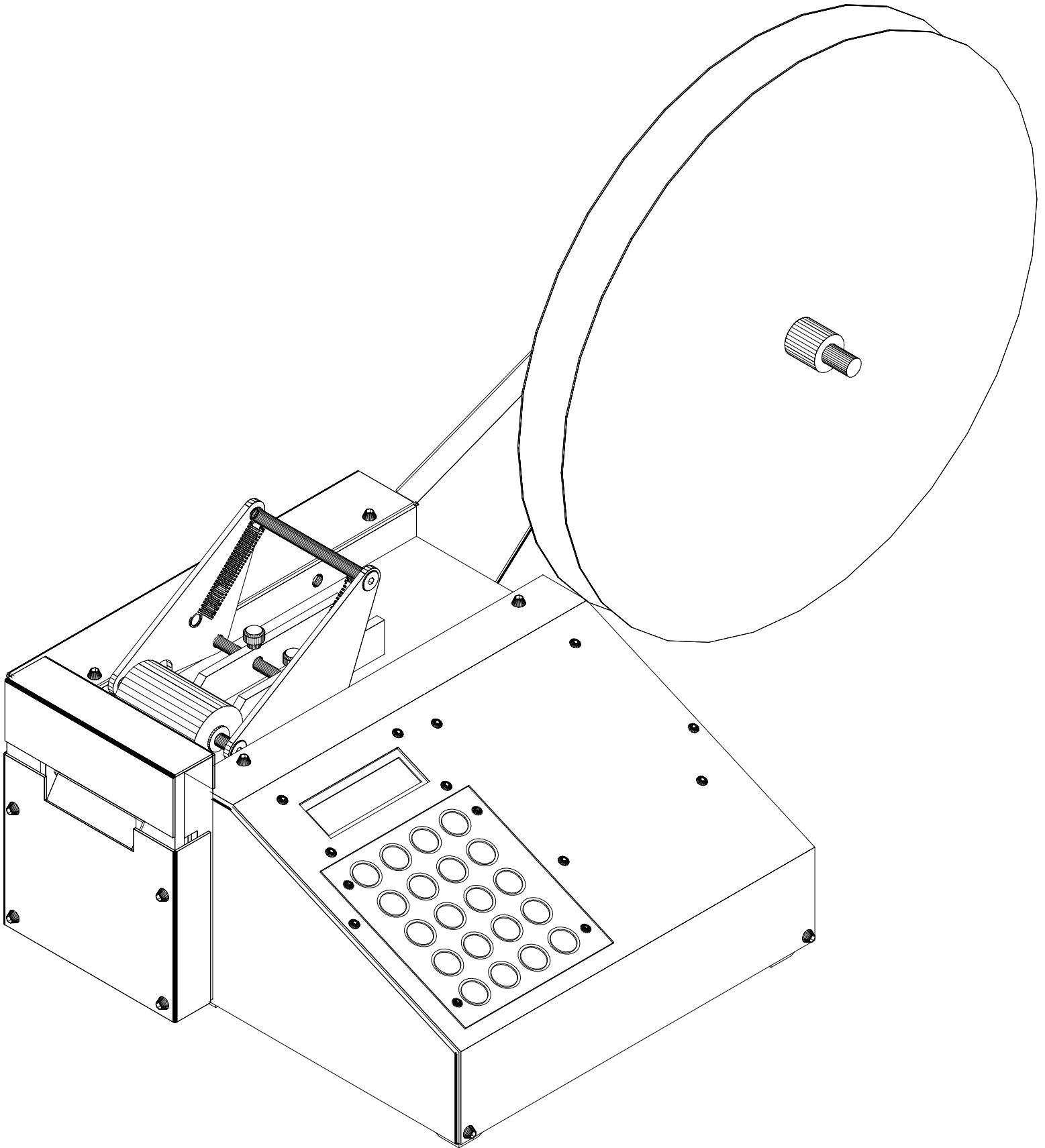

TRC's Marking Attachment



New for 2003

Just \$995.00 Installed!

Save \$100.00 when purchased with a new automatic machine.



Here's what you've been waiting for! Now cut your material to length and mark it too, all in one easy operation! Mark your material for secondary operations or fold back marks for sewing.

The new marking attachment for TRC 1000 machines is now available. This attachment allows programming of 10 marks per piece cut. Marks are placed on material with an easily changed fast drying valve type marking pen available in several colors to contrast or blend in with your specific material. The firmware also allows the machine to be used in the standard mode without marking. The marker assembly can be adjusted to place the dot in the middle of the material, on the edge of the material, or anywhere in between. Additional marker assemblies can be added for customers who cut and mark more than one roll of material at a time. The marking pens have replaceable tips that are available in fine point or large point.

The marking system comes complete with its own air pressure regulator and solenoid valve with flow controls so you can adjust the power and speed of the marking attachment. In addition the firmware allows a variable marking time for total control of the mark.

Installation:

A new top roller with a groove in it is required to make sure the mark does not get smudged, or we can groove your existing top roller. Your control panel will have to be sent to us for installation of the marking firmware and additional components and connector. The actual mechanical components can be easily bolted on to your cutting head following our detailed instructions or you can send that to us too, for a complete ready to use installation. Turn around time will vary, but normally should only be a day or two.

Custom Firmware:

As always, custom firmware is available. So if you need more marks per piece or some other special function. Send us the specifications for your requirements so we can quote your custom application.



Specifications:

- Marks per length cut: 10
- Air Pressure required: 25-35 psi
- Mark dimensions: small point - 1/8" diameter dotlarge point - 1/4" diameter dot
- List Price: \$995.00 Installed
- Price with any automatic machine: \$895.00
- Comes with 2 markers of your color choice
- Marking Pens: \$6.00 ea