

## ***SET UP PROCEDURES FOR THE TRC 1000***

### ***Model HC4-CS/VS***

1. Place *control panel* and *cutter* on a flat table with the back of the *control panel* facing the side of the *cutter*. Plug the black *heater cord* coming out the back of the *cutter* into the *control panel*. Next, connect the *control panel* to the *cutter* using the grey *control cable*. Plug the appropriate end of the *power cord* into the *fused power receptacle* on the *control panel* and the other end into a 110V outlet.

BE SURE ALL CABLES ARE SECURELY FASTENED **BEFORE** TURNING ON THE POWER.

2. Next hook up the *air regulator* to your air supply and set the pressure at 35 PSI.  
3. Set the *roll stand* behind the *cutter* and line it up with the *guides* on the *cutter*. Place one *plastic disk* on the *roll stand* and put on the roll of webbing so that the webbing rolls off the top of the roll. Place the other *plastic disk* on the *roll stand* and put the *roll holder* lightly against the *disk* and tighten the *thumb screw* lightly. If the webbing does not turn freely then loosen the *roll holder* a little.

### ***START UP PROCEDURES***

1. Turn *master switch* to **ON** position  
2. Set the *temperature control knob* to 3 - 3.5 and allow 10 - 15 min. for the knife to heat up.

**NEVER ALLOW THE KNIFE TO BECOME RED HOT AS THIS MAY CAUSE THE WEBBING TO CATCH ON FIRE.**

Use just enough heat to cut the webbing and to keep the *knife blade* burned clean. You will have to experiment with the webbing you are using to find the exact temperature that works best.

3. Adjust the *guide strips* to fit the webbing you are using. Do not make it too tight as to cause drag on the webbing.  
4. Feed the webbing through the *guides* and push it up to the *feed rollers* and then push the **FEED JOG** button on the *control panel*. This will take the webbing through the *feed rollers*. Take the webbing past the *rollers* an inch or so. You can also put the webbing through the *rollers* by pushing down on the *black knob* and lifting the *rollers* and pushing the webbing through.

Note: If your *machine* is equipped with the optional *cutoff switch*, you must feed material under the *trip rod* before the *guides*.

### ***KEYBOARD COMMANDS***

**FEED JOG** Allows you to manually operate the *feed rollers*

**KNIFE JOG** Allows you to manually operate the *knife*

**RE-SET** Allows you to clear the *machine* and start a new program

**STOP** Allows you to stop the *machine* and save all data in the memory  
Also allows you to clear a data entry while programming.

**ENTER** Allows you to enter program data

**SETTING FEED RATE**  
(for *Variable Speed models only*)

When the *control panel* is turned on the *LCD* will read "**FEED RATE 1-9**". This will determine how fast the webbing will feed through the *machine*. **1** will be the slowest and **9** will be the fastest. To enter the speed, push the number you desire and it will automatically be entered.

**ENTERING A PROGRAM**

1. When the *Master Switch* is on the *LCD* will read "**LENGTH**". To enter the length you want say a 15" piece just push 15 on the *keypad* and **ENTER**.
2. Next, "**HOW MANY**" will appear on the *LCD*. This is the number of pieces that you want to cut. If you want 100 pieces, push **100** and **ENTER** on the *keypad*.
3. "**CUT TIME**" will appear on the *LCD* last.

Cut times are in seconds. To enter 1 and 1/2 seconds, push **1.5** and **ENTER**.

Cut times will vary with the thickness of the webbing and some trial and error is necessary to get the proper cut time. 1" medium weight poly pro webbing will cut in about .75 seconds or 3/4 of a second.

**BEFORE** you push enter on the **CUT TIME** put the webbing up to the *feed rollers* and push **FEED JOG**. Once the webbing is through the knife about 3" push **KNIFE JOG** and cut off the webbing. This will give you a fresh cut to start with. Now push **ENTER** and the *machine* will start cutting. When the number of pieces that were entered have been cut the *machine* will stop. You wish to run the same program again just push **ENTER** and it will run the same program again and maintain a running count.

4. To stop the *machine* during operation and not loose the data you have entered, push the **STOP button** and hold it down until the *machine* stops.

If you need to make an emergency stop push **RESET** or turn the *master switch* off. By using the **STOP button** you will save the program and the count. To start the program again just push **ENTER** and it will continue with the program you had entered. When you use **RESET** or the *master switch* you will loose the program. After you have ran a program and want to run the same program again, you do not have to enter the data again. Just push **ENTER** and it will run the same program and continue to keep a running count.

5. When you are through with the *machine* turn the *Temperature control* to **OFF** and switch the *Master Switch* **OFF**.

## ***Procedimiento para calibrar el TRC 1000***

### ***Modelo(s) HC4-CS/VS***

1. Coloque el tablero de control y la cabeza de corte sobre una superficie plana con la parte trasera del tablero de control hacia el lado de la cabeza de corte. Enchufe el cable negro del calentador que sale de la parte trasera de la cortadora en el tablero de control. A continuacion, enchufe el tablero de control a la cortadora usando el cable de control gris. Enchufe la punta apropiada de la extension electrica al receptaculo que contiene el "fuse" en el tablero de control y en otro extremo en el receptaculo de 110V.

#### **ASEGURESE DE QUE TODAS LAS CONECCIONES ESTEN APRETADAS Y SEGURAS ANTES DE PRENDER LA MAQUINA!**

2. A continuacion, conencte el regulador de aire al suministro de aire y fije la presion a 35 PSI.  
3. Coloque el soporte del rodillo atras de la cortadora y alineeelo con la guias en la cortadora. Coloque un disco de plastico en el soporte del rodillo y ponga un rollo de hilaza de manera que el rollo de hilaza se desenrolle de la punta del rodillo. Coloque el otro disco de plastico en el soporte del rodillo y ponga el soporte del rodillo ligeramente contra el disco. Apriete el tornillo de ajuste ligeramente. Si el rollo de hilaza no se desenrolla libremente, entonces afloje ligeramente el soporte del rollo.

#### ***Procedimiento para comenzar***

1. Posicione el switch de control en la posicion "ON"  
2. Mueva el perno de control de temperatura a 3-3.5 y permita 10-15 minutos para que se caleinte la navaja. **NUNCA PERMITA QUE LA NAVAJA SE CALIENTE DEMASIADO (COLOR ROJO), YA QUE ESTO PUEDE OCASIONAR QUE LA HILAZA SE QUEME.** Solamente use suficiente calor para cortar la hilaza y mantenga la navaja libre de quemaduras. Se tendra que experimentar con la hilaza que se esta usando para encontrar la temperatura ideal.  
3. Ajuste las guias de acuerdo a la hilaza que se esta usando. No lo apriete mucho de manera que arrastre la hilaza.  
4. Alimente la hilaza a traves de las guias y empujela hacia los rodillos de alimentacion, entonces empuje el boton "Feed Jog" en el tablero de control. Esto llevara la hilaza a traves de los rodillos de alimentacion. Alimente la hilaza hasta pasar los rodillos una pulgada y apriete el boton "Knife Jog". Ud. Tambien puede poner la hilaza a traves de los rodillos empujando hacia abajo el perno negro y levantando los rodillos y empujando la hilaza con la mano.  
Nota: Si la maquina esta equipada con el switch opcional de apagado, se debe de alimentar el material bajo la varilla de viaje antes de las guias.

#### ***Tablero de comandos***

<b>Feed Jog</b>	Permite la operacion manual de los rodillos alimentadores
<b>Knife Jog</b>	Permite la operacion manual de la navaja
<b>Re-set</b>	Permite re-iniciar la maquina y comenzar un nuevo programa
<b>Stop</b>	Permite parar la maquina y guardar los datos en la memoria. Tambien permite borrar una paso no deseado durante su programacion.
<b>Enter</b>	Permite entrar datos del programa

***Calibrando la velocidad de alimentacion***  
*(Solo para modelos con velocidad variable)*

Cuando el tablero de control esta prendido, el LCD (display de cristal liquido) lee "FEED RATE 1-9". Esto deterrinara que tan rapido la hilaza pasara a traves de la maquina. 1 = mas lenta y 9 = mas rapida. Para fijar la velocidad, empuje el numero deseado y se fijara automaticamente.

***GRABANDO UN PROGRAMA***

1. Cuando el switch universal esta prendido, el LCD leera "LENGTH"(LONGITUD). Para fijar el numero deseado, por ejemplo una pieza de 15 pulgadas, marque 15 en el tablero numerico y apriete "ENTER".
2. A continuacion. "HOW MANY" (CUANTAS) aparecera en el LCD. Este el numero de piezas que se van a cortar. SI se qieren 100 piezas, marque 100 y "ENTER" en el tablero numerico.
3. Al final, "CUT TIME" (DURACION) aparecera en el LCD. ". Esta es la duracion de tiempo que la navaja se encuentra abajo para cortar la hilaza. Tiempos de duracion son en segundos. Para marcar 1 y ½ segundos, marque 1.5 y "ENTER. La duracion de corte varia de acuerdo al grosor y al ancho de la hilaza. Por ejemplo, un material ligero podria tomar 0.10 segundos para cortar, mientras que un material mas grueso puede tomar 0.250 segundos para cortar. Es necesario experimentar un poco para encontrar el mejor tiempo de corte para su material. Hilaza "poly-pro" de 1 pulgada de peso medio se cortara de .75 segundos a ¾ de segudo. ANTES, de marcar "ENTER" en el "CUT TIME" ponga la hilaza hasta los rodillos de alimentacion y empuje "FEED JOG". Una vez que 3 oulgadas la hilaza han pasado la navaja, apriete "KNIFE JOG" y corte la hilaza. Esto le proporcionara un corte limpio para comenzar. Ahora apriente "ENTER" y la maquina comenzara a cortar. Cuando el numero de piezas deseadas se han cortado, la maquina se parara. Si, Ud. Desea repetir el programa otra vez empuje "ENTER" y repetira el mismo programa y mantendra la cuenta. Para obteuer 0.10 segundos tiempo de corta, entre \*10 despues de que "Cut Time?" aparece en el LCD,
4. Para parar la maquina durante la operacion sin perder la informacion fijada, apriete el boton de STOP y mantengalo apretado hasta que la maquina pare completamente.. Si se necesita hacer una parada de emergencia apriete RESET o apague el switch universal. Mediante el use del boton STOP, no se perdera el programa ni la cuenta. Para reanudar, apriete ENTER y continuara con el programa previamente indicado. Cuando de usa RESET o el switch universal, se perdera el programa. Despues de que se ha corrido un programa y quiere correr el mismo programa otra vez, no se necesita meter la informacion nuevamente. Simplemente apriete ENTER y corra el mismo programa y continuara una cuenta corrida.
5. Cuando acabe de usar la maquina coloque el control de temperatura y el switch universal en la posicion "OFF".

## ***SET UP PROCEDURES FOR THE TRC 1000***

***Model HC4-CS/VS***

**VS 3.0**

1. Place *control panel* and *cutter* on a flat table with the back of the *control panel* facing the side of the *cutter*. Plug the black *heater cord* coming out the back of the *cutter* into the *control panel*. Next, connect the *control panel* to the *cutter* using the gray *control cable*. Plug the appropriate end of the *power cord* into the *fused power receptacle* on the *control panel* and the other end into a 110V outlet.

BE SURE ALL CABLES ARE SECURELY FASTENED **BEFORE** TURNING ON THE POWER.

2. Next hook up the *air regulator* to your air supply and set the pressure at 35 PSI.  
3. Set the *roll stand* behind the *cutter* and line it up with the *guides* on the *cutter*. Place one *plastic disk* on the *roll stand* and put on the roll of webbing so that the webbing rolls off the top of the roll. Place the other *plastic disk* on the *roll stand* and put the *roll holder* lightly against the *disk* and tighten the *thumb screw* lightly. If the webbing does not turn freely then loosen the *roll holder* a little.

### ***START UP PROCEDURES***

1. Turn *master switch* to the **ON** position  
2. Set the *temperature control knob* to 3 - 3.5 and allow 10 - 15 min. for the knife to heat up.

**NEVER ALLOW THE KNIFE TO BECOME RED HOT AS THIS MAY CAUSE THE WEBBING TO CATCH ON FIRE.**

Use just enough heat to cut the webbing and to keep the *knife blade* burned clean. You will have to experiment with the webbing you are using to find the exact temperature that works best.

3. Adjust the *guide strips* to fit the webbing you are using. Do not make it too tight as to cause drag on the webbing.

4. Feed the webbing through the *guides* and push it up to the *feed rollers* and then push the **“Feed Jog”** button on the *control panel*. This will take the webbing through the *feed rollers*. Take the webbing past the *rollers* an inch or so. You can also put the webbing through the *rollers* by pushing down on the *black knob* and lifting the *rollers* and pushing the webbing through.

Note: If your *machine* is equipped with the optional *cutoff switch*, you must feed material under the *trip rod* before the *guides*.

### ***KEYBOARD COMMANDS***

- “**Feed Jog**” Allows you to manually operate the *feed rollers*
- “**Knife Jog**” Allows you to manually operate the *knife*
- “**Reset**” Allows you to clear the *machine* and start a new program
- “**Stop**” Allows you to stop the *machine* and save all data in the memory  
Also allows you to clear a data entry while programming.
- “**Enter**” Allows you to enter program data

### **SETTING FEED RATE** (for Variable Speed models only)

When the *control panel* is turned on the *LCD* will read "**Feed Rate 5-22?**". This will determine how fast the webbing will feed through the *machine*. **5** will be the slowest and **22** will be the fastest. To enter the speed, push the number you desire and press the “**Enter**” key.

### **ENTERING A PROGRAM**

1. When the *Master Switch* is on the *LCD* will read "**Length?**". To enter the length you want, say a 15" piece, just push 15 on the *keypad* and press “**Enter**”.
2. "**Cut Time?**" will appear on the *LCD* next.  
Cut times are in seconds. To enter 1 and 1/2 seconds, push **1.5** and press “**Enter**”.  
Cut times will vary with the thickness of the webbing and some trial and error is necessary to get the proper cut time. 1" medium weight poly pro webbing will cut in about .75 seconds or 3/4 of a second.
3. Next, "**How Many?**" will appear on the *LCD*. This is the number of pieces that you want to cut. If you want 100 pieces, push **100** and “**Enter**” on the *keypad*.

**BEFORE** you push enter on the "**How Many?**" put the webbing up to the *feed rollers* and push “**Feed Jog**”. Once the webbing is through the knife about 1" push “**Knife Jog**” and cut off the webbing. This will give you a fresh cut to start with. Now push “**Enter**” and the *machine* will start cutting. When the number of pieces that were entered have been cut the *machine* will stop. If you wish to run the same program again, just push “**Enter**” and it will run the same program again and maintain a running count.

4. To stop the *machine* during operation and not loose the data you have entered, push the “**Stop**” *button* and hold it down until the *machine* stops.

If you need to make an emergency stop push “**Reset**” or turn the *master switch* off. By using the “**Stop**” *button* you will save the program and the count. To start the program again just push “**Enter**” and it will continue with the program you had entered. When you use “**Reset**”

or the *master switch* you will lose the program. After you have ran a program and want to run the same program again, you do not have to enter the data again. Just push **“Enter”** and it will run the same program and continue to keep a running count.

5. When you are through with the *machine* turn the *Temperature control* to **OFF** and switch the *Master Switch* **OFF**.

### ***Calibration and other new features of VS 3.0***

During power up or reset, while the program version is being displayed, you may press the **“\*”** key to access the calibration entry menu. This will default to a certain value of 41.XX steps/inch depending on the machine. When changing the calibration factor, the change will only remain in memory as long as the power to the control is on or the control is reset and goes back through the version display, unless you have the non-volatile memory option.

During program entry, if you make a mistake, you can press the **“Stop”** key to clear the current data.

The first program question will be **“Feed Rate 5-22?”**. Entries of 1 to 4 will run at speed 5 and entries above 22 will default to speed 10. Speeds are measured in inches/sec. Speeds below feed rate 8-10 (depending on machine) will not ramp up or down. Higher speeds will ramp up to speed and hold, then ramp down and stop for the cut. If the desired length is not long enough for the ramp up and down, the feed rate is automatically reduced until it fits the ramp curve. For instance, a 10” piece will not be able to ramp up to a speed of 22. Therefore the feed rate will be reduced to about 10.

The next question is **“Length?”**, followed by the **“Cut Time?”** and the Final question is **“How Many?”**. To allow for calibrating the machine follow this guide line.

Enter **“1”** for **“How Many?”** and press the **“Enter”** key and run the part.

(Control is now in the ‘waiting’ loop)

Measure the part. If the part is too short or too long you can adjust the calibration factor and run another for comparison. The following options are available in the ‘waiting’ loop

Pressing **“1”** will increase the calibration factor by .01

Pressing **“2”** will decrease the calibration factor by .01

Pressing **“3”** will allow you to re-enter the quantity needed

Pressing **“4”** will display the current calibration factor

Note: When pressing **“1”** or **“2”**, the new cal factor will be displayed for 5 seconds and return to the ‘waiting’ loop.

Once the part is cutting the correct length, press the **“3”** key and enter the quantity needed for the batch. The machine will proceed to cut the remaining parts. You should record the calibration factor for future reference.

# Models HC4-CS HC4-VS

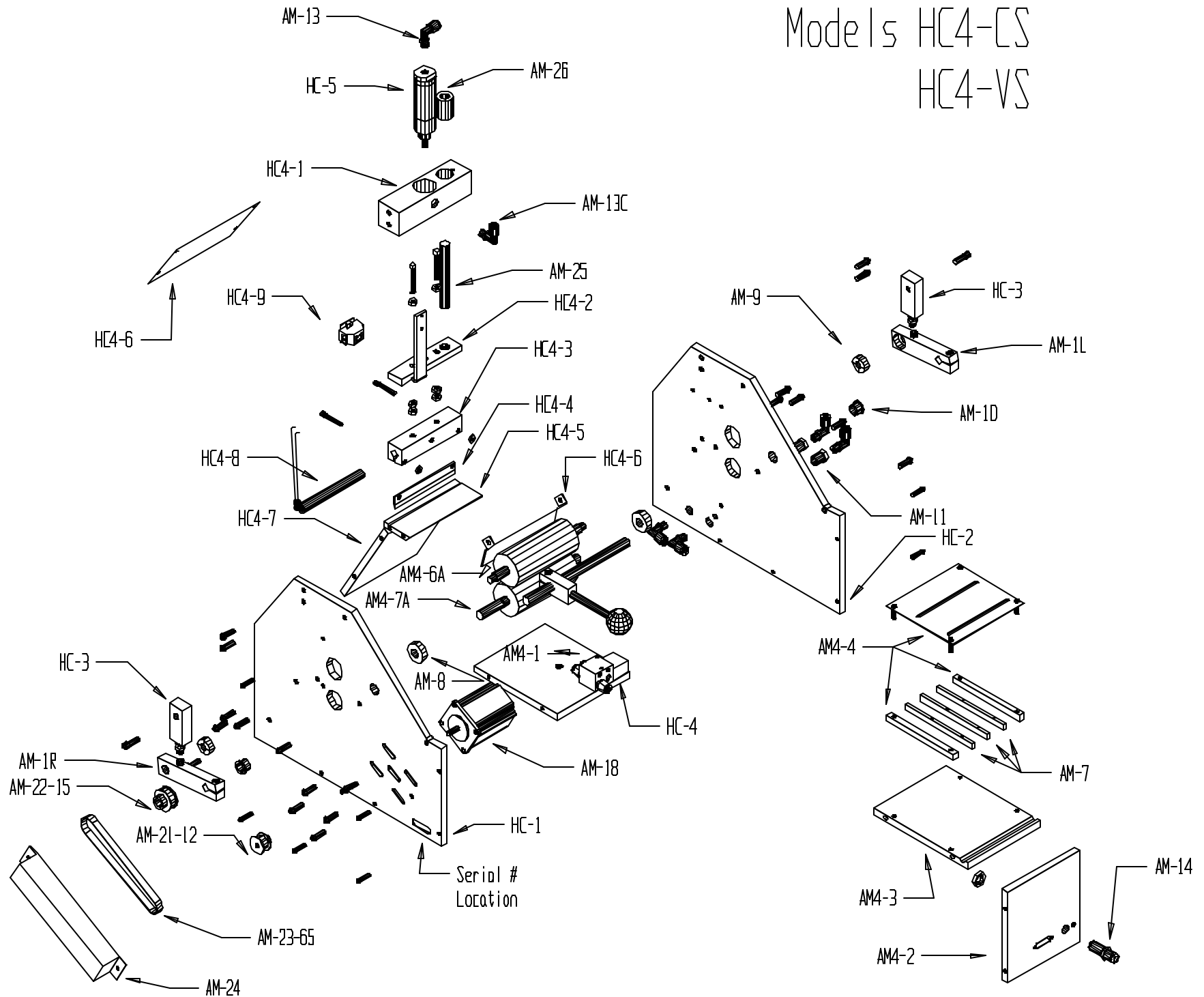



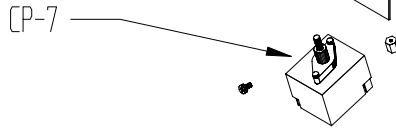
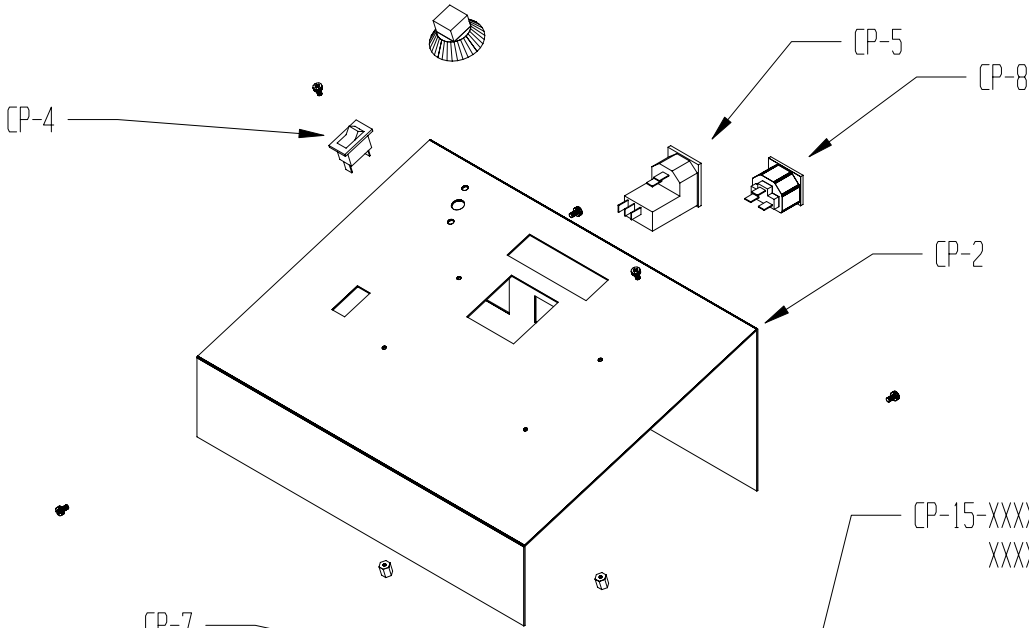

CP-15-XXXX  
 XXXX = CS Constant Speed  
 CSHT Constant Speed High Torque  
 VS Variable Speed  
 VSHT Variable Speed High Torque  
 VSAA Variable Speed Alternating Angle

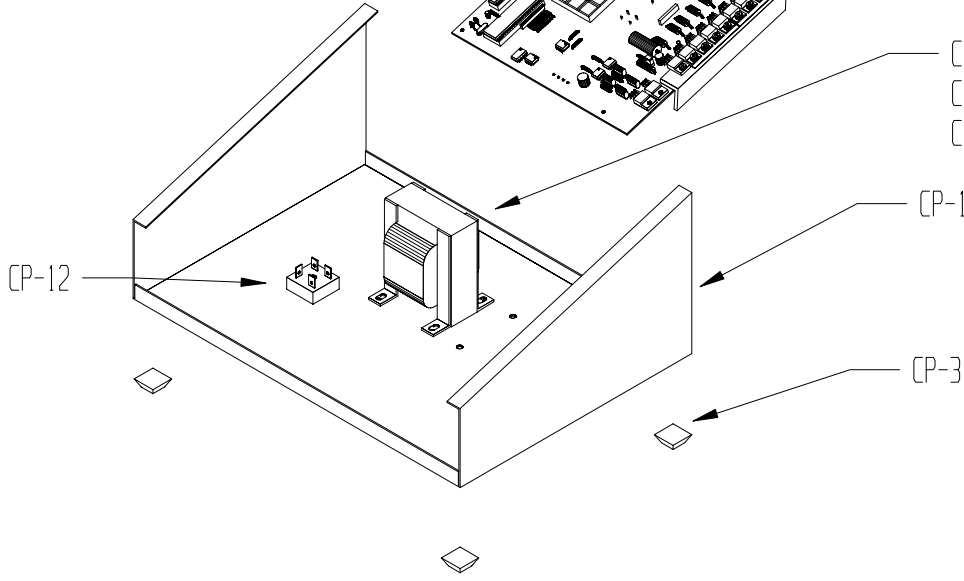

CP-9 CS and CSHT  
 CP-10 VS and VSAA  
 CP-11 VSHT

## **Periodic Maintenance**

Proper operation of your *TRC-1000* can be maintained by periodic cleaning, lubrication and adjustment of the *Cutting Unit*.

*Linear Shafts/Bushings* and *Air Cylinder shafts* should be kept clean of dust, lint and other foreign substances. These points should also be lubricated periodically with a light weight oil, such as sewing machine oil.

Keep *Drive* and *Tension Rollers* clean of foreign matter. Proper *spring* tension is also important to machine accuracy. Too much pressure causes excessive drag, and too little will cause material slippage.

*Drive Belt* and *Pulleys* should be checked for slippage and looseness.

The *Cutting Blade* and Groove on the *Cutting Plate* should be scraped clean.

Periodically check all *screws* for loosening.

## *Spring Tension Adjustment*

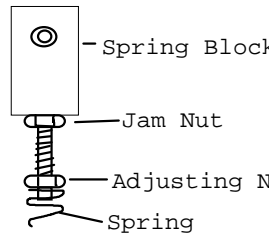

- 1) Loosen jam nut.
- 2) Screw bolt in or out with adjusting nut to decrease/increase spring pressure on top roller. (adjust both sides evenly.)
- 3) Snug jam nut.

**Note: Excessive roller tension promotes feed roller wear and motor load!**

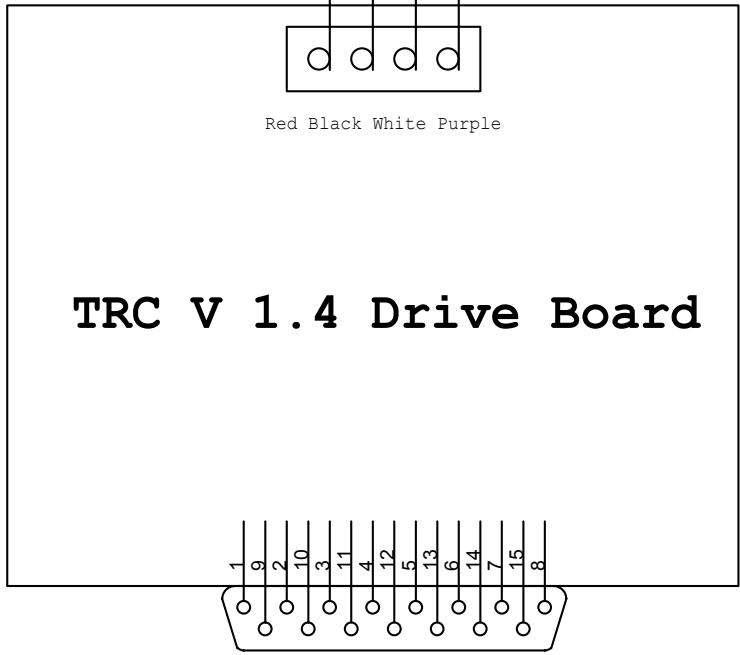
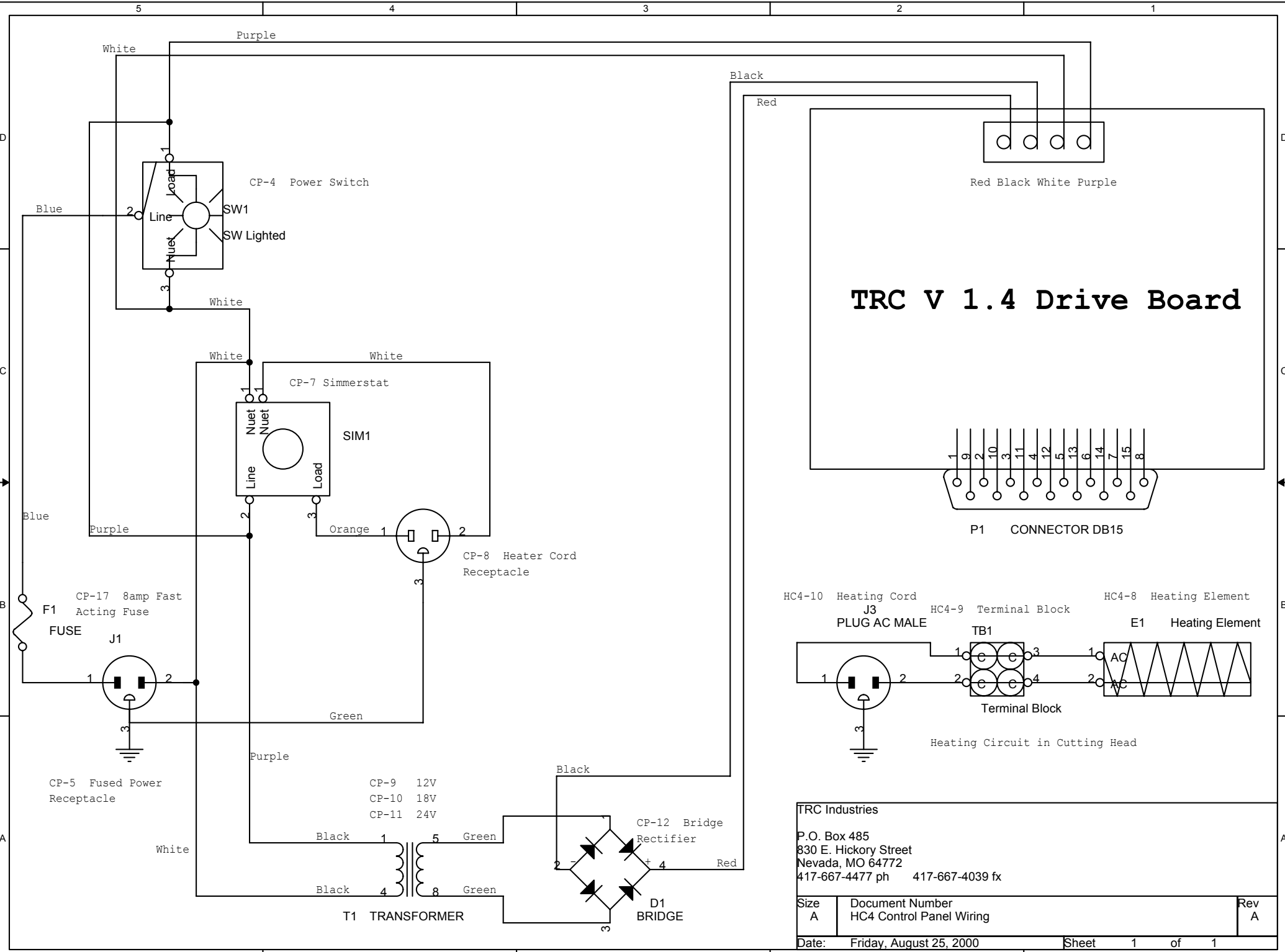

# TRC V 1.4 Drive Board

P1 CONNECTOR DB15

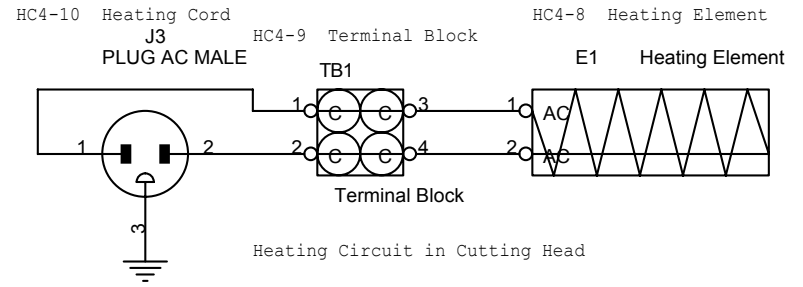

Heating Circuit in Cutting Head

TRC Industries		
P.O. Box 485 830 E. Hickory Street Nevada, MO 64772 417-667-4477 ph 417-667-4039 fx		
Size A	Document Number HC4 Control Panel Wiring	Rev A
Date: Friday, August 25, 2000	Sheet 1 of 1	1

***TRC Industries***

---

***Factory Warranty Registration Card***

Company Name \_\_\_\_\_  
Address \_\_\_\_\_  
City, ST, Zip \_\_\_\_\_

Phone \_\_\_\_\_ Email Address \_\_\_\_\_  
Fax \_\_\_\_\_ Website \_\_\_\_\_  
Contact Person \_\_\_\_\_

Date Purchased \_\_\_\_\_ Dealer Name \_\_\_\_\_  
P.O. # \_\_\_\_\_ Address \_\_\_\_\_  
Model \_\_\_\_\_ City, ST, Zip \_\_\_\_\_  
Serial # \_\_\_\_\_  
Phone \_\_\_\_\_  
Fax \_\_\_\_\_  
Salesman \_\_\_\_\_

Mail to:  
TRC Industries  
P.O. Box 485  
Nevada, MO 64772

or Fax to 417-667-4039

Atten: Jon

Please visit our Page on the Internet at  
<http://www.trcind.com>  
or email us at  
[register@trcind.com](mailto:register@trcind.com)